

# IK-CHINA LIMITED 上海石高有限公司

The unique data book containing comprehensive information and comparison tables fin tubes, equipment and related products according to main international standards.



## General Catalogue

# **IK-CHINA LIMITED**

## **上海石高有限公司**

Luoshe town, Huishan economic development zone, Wuxi city, Jiangsu province, China 214187  
中国江苏省无锡市惠山经济开发区洛社 邮编214187

Phone 电话: +86-1811-539-6071

Fax 传真: +86-510-68930106

E-mail [info@magvant.com](mailto:info@magvant.com)

Web [www.magvant.com](http://www.magvant.com)



# IK-CHINA LIMITED

## 上海石高有限公司

*Magvant* IK-CHINA LIMITED is high-tech enterprises with capacity of design, research and development, production and sales, and pass ISO9001: 2008 quality system certification. Main products are various types of finned tubes , heat pipes and heat transfer equipment , tube finning machines, fiberglass pulltrusion mold and other quality and reliable products.

*Magvant* IK-CHINA depends on industry association, professional collaboration and combining research and production, give full play to the advantage of the heat exchanger products and become bigger, stronger, our company has invested and participate to build independent operation union company in Jiangsu, shanghai. Products scales has been greatly expanded. We have 15 tube finning production lines for finned tubes made of steel and aluminum, 2 production lines of nickel based brazing fin tubes, 6 automatic production line of high frequency welded spiral finned tube, with the capacity of over 10000 meters of finned tubes made of steel and aluminum per day, and 5,000 tons of carbon steel, low alloy steel or stainless steel welded spiral finned tubes and capacity of various equipment for heat exchange use. Our products are sales to both domestic and oversea countries like America, Canada, south America, Europe, Asia, Australia and the Middle East, We sincerely work with both domestic and foreign customers with quality products and services. IK-CHINA mainly serve for industries like petrochemical, power generation, equipment fabricating of heat exchangers, boilers, condensers, feed-water heaters, evaporators, air-coolers, waste heat recovery unit (whru), heat recovery stam generator(hrsg), and so on.

*Magvant* Our products have passed through the inspection of customers and third party like BV, ABS, SGS, Moody, TUV.

We take EARNEST, PROFESSIONAL, PERFECT as our motto. Our mission is to satisfy industrial developments.

*Magvant* Our success of is driven by quality, availability, productivity and a wide product range, backed by a dynamic and experienced workforce and strict management.

Luoshe town, Huishan economic development zone, Wuxi city, Jiangsu province, China 214187  
中国江苏省无锡市惠山经济开发区洛社 邮编214187

Phone 电话: +86-1811-539-6071

Fax 传真: +86-510-68930106

E-mail [info@magvant.com](mailto:info@magvant.com)

Web [www.magvant.com](http://www.magvant.com)

# Fin tubes, Equipments

**Magvant** Main products: Heat transfer equipment and accessories: seamless tubes, various pipes, heat pipes heat exchanger, air heat exchanger, high-frequency welding spiral fin tubes machine, heat exchanger components, high-frequency welded helical (spiral) fin tubes, L, LL, KL, G finned tubes (pipes), extruded fin tubes, H finned tubes (pipes), longitudinal fin tubes, heat pipe, studded tubes, pin fin tubes, spiral slot tube, laser welded finned tubes, etc.)

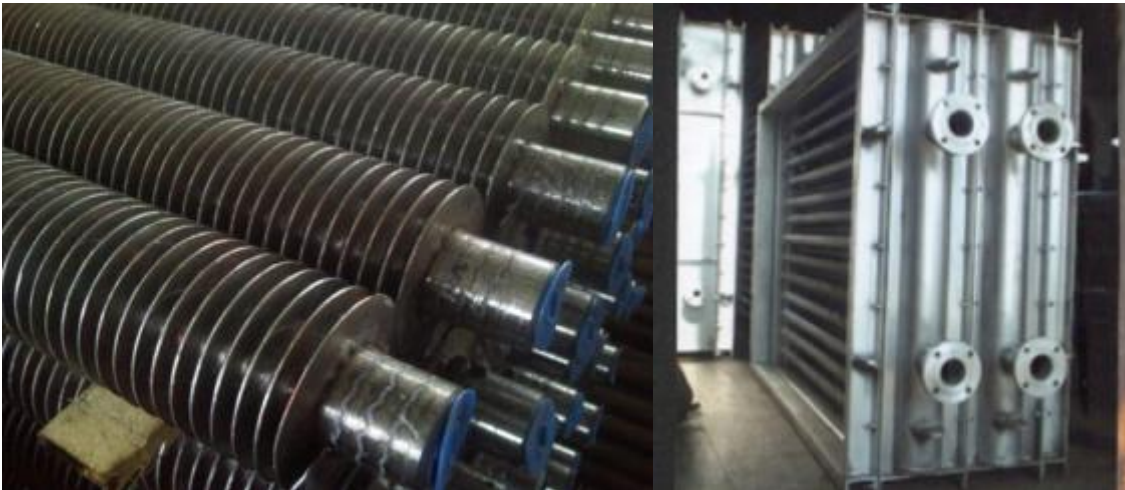

**Magvant** Fin tube drawings layout from CAD (only for reference)

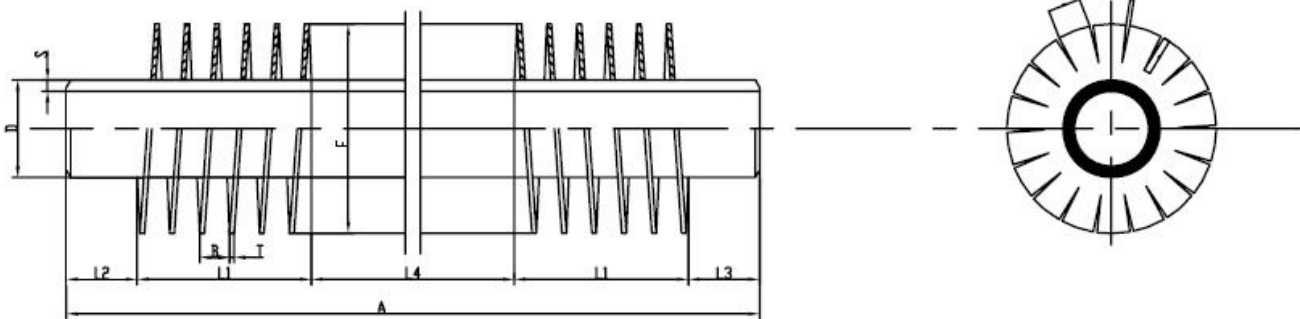

D=2"(60.3mm)  
 S=4.5mm  
 L=3900mm  
 L1=1850mm  
 L2=25mm  
 L3=25mm  
 L4=150mm  
 E=120,3mm  
 T=1.2mm  
 B=5mm

**Remarks:**

1. Tube material: ASTM A335/A335M P11
2. Fin material: AISI 409
3. Form of fin tubes: HF serrated fin tubes

IK-CHINA LIMITED			77 7	0	9.7777
			A 77	0	34 77
77 7			77 77	0	77 77
77 77					

# Fin tubes, Equipments

High Frequency welded helical fin tubes

## **Magvant** HEAT TRANSFER ELEMENTS: HF HELICAL WELDED FIN TUBES

**Magvant** High Frequency Helical welded solid fin tubes ( finned tubes ) and Serrated Finned tubes (finned tubes)

**Magvant** We produce Welded Finned pipes and Tubes in many different diameters and fin configurations and metal combinations to meet your heat transfer needs.

**Magvant** welded spiral fin tubes ( finned tubes )( TECHNIFIN TYPE WO“, WOS“, LFS“, ) manufacturing capabilities for helical solid fin tubes ( finned tubes ) and serrated finned tube:

**Magvant** High-frequency welding finned tubes (pipes) production range  
fin material: carbon steel, corrosion-resistant steel, stainless steel, alloy steel  
welding finned forms: real teeth, opened teeth(serrated fin tubes)

**Magvant** Frequency welding spiral fin tubes (pipes) is a highly efficient heat transfer components. Its heat transfer area of the optical tubes (pipes) several times or more, enhanced heat transfer, reducing the flow resistance, reducing the metal consumption, thus improving the economy and operational reliability of the heat transfer equipment. At present, high frequency welding spiral fin tubes has been widely and has been widely used in a variety of chemical, electric power, metallurgy, petrochemical, boiler, building materials, textile, environmental protection, dry, medical field.

**Magvant** general used materials:

### **Supply Range of base tubes (pipes) (core tube):**

Carbon Steel ASTM A 179, ASTM A 192, ASTM A 210 Gr. A1, ASTM A 210 Gr. C, ASTM A 106 Gr. B

Low Alloy Steel ASTM A 209 T1, ASTM A 213 / A 199 T11/T12, ASTM A 213 / A 199 T22, ASTM A 213 / A 199 T5, ASTM A 213 / A 199 T9, ASTM A 335 P1 / A 161 T1, ASTM A 335 P11 / P12 / A 200 T22, ASTM A 335 P22 / A 200 T22, ASTM A 335 P5 / A 200 T5, ASTM A 355 P9 / A 200 T9

Stainless Steel ASTM A 213 / A 312 TP 304I, ASTM A 213 / A 312 TP 304L, ASTM A 213 / A 312 TP 321, ASTM A 213 / A 312 TP 316, ASTM A 213 / A 312 TP 316L, ASTM A 213 / A 312 TP 347, ASTM A 213 / A 312 TP 316Ti, ASTM A 289 / A 790 UNS S 31803, ASTM B 677 Alloy 904L

Nickel ASTM B 161 Ni 200, ASTM B 161 Ni 201

The Diameter of pipes mm	pipes wall thickness mm	Finned tubes (pipes) lengthm	Fin height mm	Fin thickness mm	Fin spacing mm	Fin tooth width mm
OD16-OD273	2-30	up to 30	5-30	0.5-3	2.8-50	4.4-7.9

**Magvant**



Solid fins: HF (high frequency) welded helical (spiral) fin tubes ( finned tubes )



Serrated fins: HF (high frequency) welded helical (spiral) fin tubes ( finned tubes )

# Fin tubes, Equipments

## High Frequency welded helical fin tubes

**Magvant** HEAT TRANSFER ELEMENTS: HF HELICAL WELDED FIN TUBES

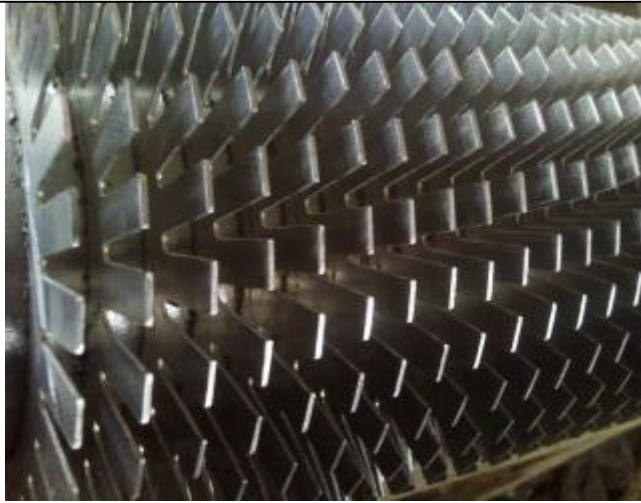

HF (high frequency) welded helical (spiral) fin tubes ( finned tubes )



HF (high frequency) welded helical (spiral) fin tubes ( finned tubes )



HF (high frequency) welded helical (spiral) fin tubes ( finned tubes )



HF (high frequency) welded helical (spiral) fin tubes ( finned tubes )

**Magvant** Cutting & Beveling, Bending, Threading & Coupling, Vitalium Coupling, Cleaning

### **Magvant** NICKEL BRAZING OSNOSIS LAYER FINNED TUBES:

**Magvant** welding ratio between tubes (pipes) and fins is 100%, no thermal contact resistance, contact resistance of 0, significantly less than the high-frequency welding and copper alloy welding fin tubes (pipes) thermal resistance, similar with single metal finned tubes; welding parts smooth, uniform layer of alloy infiltration, .....Working temperature is about 500 to 600 degree.

Laser welded finned tubes

# Fin tubes, Equipments

## L,LL,KL, FIN TUBES

### **Magvant HEAT TRANSFER ELEMENTS: L,LL,KL, FIN TUBES ( FINNED TUBES )**

fin tubes ( finned tubes )'s fin type: L/LL/KL fin tubes ( finned tubes ) (with aluminum fins)

#### **Magvant Core Tubes**

Carbon steels (ASTM A 179/ A 214, St 35.8,etc.), low-alloy steels, stainless steels, copper-nickel alloys, aluminum bronze, copper, nickel-alloys(Alloy 400, ext.), bimetal

**Magvant Fins:** Aluminum ASTM B209 Al 1060; ASTM B209 Al 1100, 1050A.

#### **Magvant FIELDS OF APPLICATION**

- . the petroleum, chemical and petrochemical process industries
- . natural gas treatment
- . the steel industry: blast furnace and converter systems
- . power generation: steam turbine exhaust condensing
- contact condensing with cooling of circulating condensate
- fossil and nuclear power plants
- . air conditioning (Freon, ammonia, propane)
- . incineration of household refuse
- . compressor coolers, etc.

#### **Magvant MANUFACTURING PROCESS**

The manufacturing strip is folded to form an L shape and then wound around the base tubes (pipes) (core tube). The feet of the fins are joined together and cover the whole of the finned surface. Both lends are clamped down to avoid unrolling through damage.

#### **Magvant ADVANTAGES**

Economic This method of manufacturing enables us to place the finning on a very thin-walled tubes (pipes) with is particularly desirable when using noble alloys(titanium, stainless, copper, nickel).

The tubes (pipes) can withstand a temperature of up to 130°C without the risk of atmospheric corrosion or thermal stress. L1 max. = 12 000 mm Fin Thickness = 0,3 - 0,4 mm Fa = Outer tubes (pipes) Surface Area incl. Surface Area of Fins L2 max. = L1 -2t x = acc. to clients specification Fi = Interior tubes (pipes) Surface Area per Meter (m<sup>2</sup>/m) FZR = Uncovered tubes (pipes) Area between the fins. Increased contact surface and improved lock of the fin base in the axial surface of the tube. Improved fin bond stability at higher temperatures. More stable during application process than Wrap-On Fin.

**Magvant general used materials:**

#### **Supply Range of base tubes (pipes) (core tube):**

Carbon Steel ASTM A 179, ASTM A 192, ASTM A 210 Gr. A1, ASTM A 210 Gr. C, ASTM A 106 Gr. B

Low Alloy Steel ASTM A 209 T1, ASTM A 213 / A 199 T11/T12, ASTM A 213 / A 199 T22, ASTM A 213 / A 199 T5, ASTM A 213 / A 199 T9, ASTM A 335 P1 / A 161 T1, ASTM A 335 P11 / P12 / A 200 T22, ASTM A 335 P22 / A 200 T22, ASTM A 335 P5 / A 200 T5, ASTM A 355 P9 / A 200 T9

Stainless Steel ASTM A 213 / A 312 TP 304I, ASTM A 213 / A 312 TP 304L, ASTM A 213 / A 312 TP 321, ASTM A 213 / A 312 TP 316, ASTM A 213 / A 312 TP 316L, ASTM A 213 / A 312 TP 347, ASTM A 213 / A 312 TP 316Ti, ASTM A 289 / A 790 UNS S 31803, ASTM B 677 Alloy 904L

Nickel ASTM B 161 Ni 200, ASTM B 161 Ni 201



## Fin tubes, Equipments

L,LL,KL, FIN TUBES

---

**Magvant** HEAT TRANSFER ELEMENTS: L,LL,KL, FIN TUBES ( FINNED TUBES )

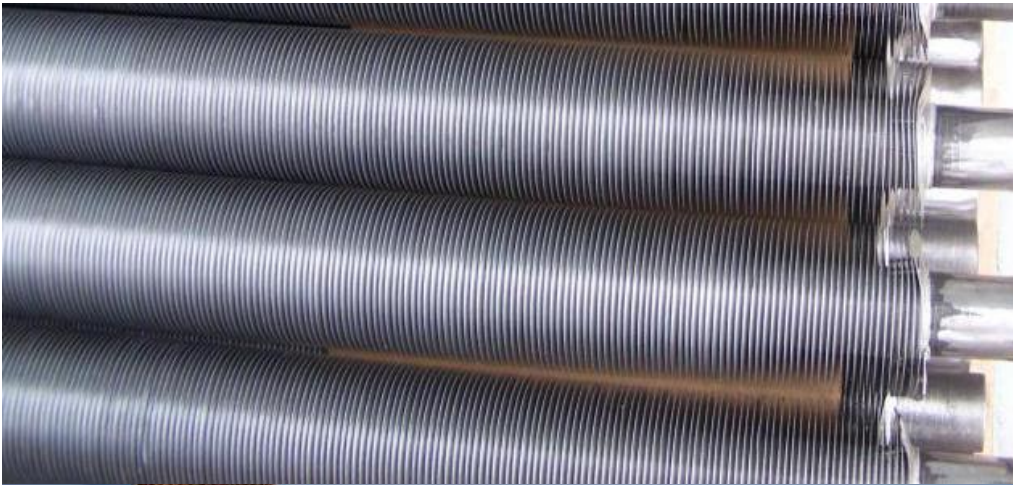



# Fin tubes, Equipments

## G embedded fin tubes

### Magvant FIN TUBE'S FIN TYPE: G EMBEDDED FIN TUBES

TECHNIFIN TYPE G“ G fin tubes (with aluminum fins)

The fin strip is wound into a mechanically produced groove and tightened by backfilling of the base material under pressure. Groove depth 0,4 mm.

G embedded fin tubes: The fin strip is wound into a mechanically produced groove and tightened by backfilling of the base material under pressure. Groove depth 0,4 mm. Advantages: High fin stability, excellent heat transfer, high operating temperature.

### Magvant MANUFACTURING PROCESS

The manufacturing tool is made up of 2 non-cutting plates set at 90° to the axis of the base tubes (pipes) (core tube). The first plate effects a groove for metal spinning. The second directs the ribbon in the groove and sets the fin foot in the groove through pressure on the metal displaced for the groove. A similar plate made of tungsten carburate allows us to manufacture. G embedded fin tubes ( finned tubes )with base tubes (pipes) (core tube) made of austenitic steel or exotic alloys.

### ADVANTAGES

- 1) Thermal The fin/tube wall contact is constant because of the setting and makes it possible to use a wall temperature of up to 400° C.
- 2) Mechanical The fin is set throughout its length and consequently does unwind even when partially uprooted.

### Magvant Material Combinations

Core Tube: Carbon steels (ASTM A 179/ A 214, St 35.8,etc.), low-alloy steels, stainless steels, copper-nickel alloys, aluminum bronze, copper, nickel-alloys(Alloy 400, ext.),

Magvant Fins:Aluminum ASTM B209 Al 1060;ASTM B209 Al 1100, A1050, etc.

Magvant Maximum operating temperature for this fin type is 450° C.

Magvant G type embedded fin tubes machine is designed by ourself based on international advanced technologies and experience with stable and firm slotting embedding technology, pulled off force not less than 70 N, medium allowable temperature of 450 °C, with strong resistant and heat-resistant ability, widely used in the impact of petrochemical refining air condenser.

G type fin tubes CAD drawing for reference

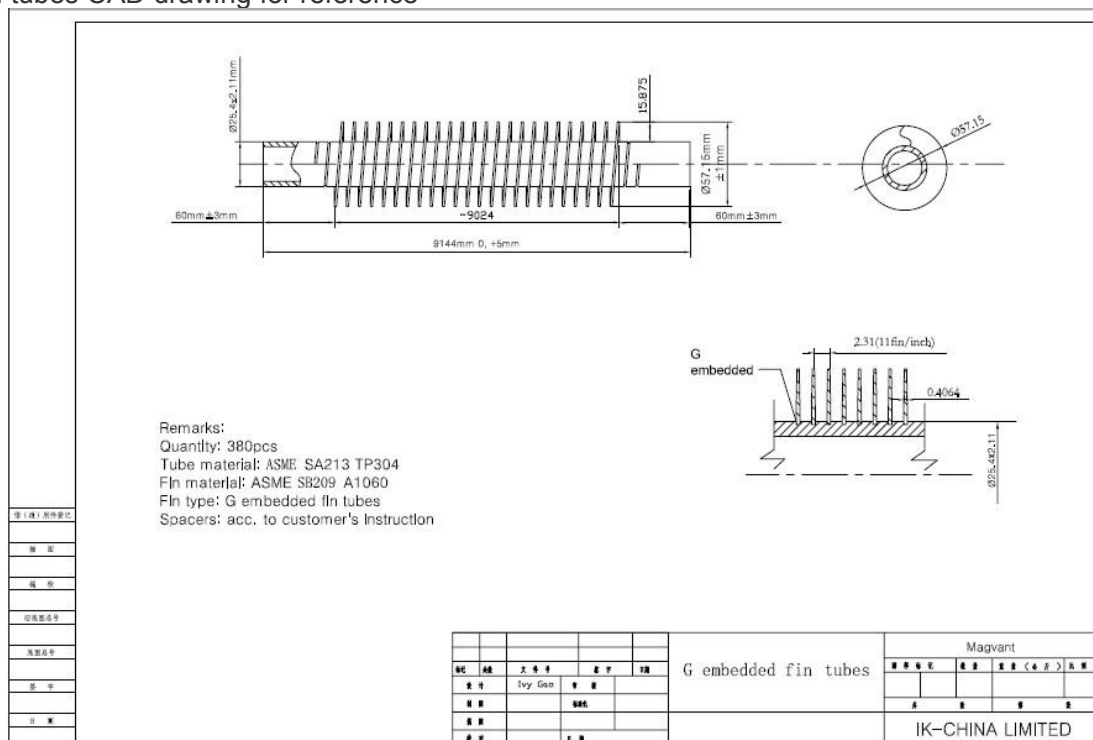

## Fin tubes, Equipments

G embedded fin tubes

**Magvant FIN TUBES'S FIN TYPE: G EMBEDDED FIN TUBES**



# Fin tubes, Equipments

## Extruded fin tubes

### Magvant HEAT TRANSFER ELEMENTS

Extruded fin tubes ( finned tubes )

fin type: extruded fin tubes and many special sizes extruded fin tubes ( finned tubes ). extruded fin tubes ( finned tubes ) has the advantages of high efficiency, strong corrosion resistant and long life as the International, technologically advanced heat transfer element. The base tubes (pipes) (core tube) of double extruded fin tubes can be SS, CS, corrosion resistant steel, copper and copper alloys, Ti and Ti alloys and the other materials. The base tubes (pipes) (core tube) of single extruded fin tubes can be copper, Nickel-copper, Aluminum and the other materials. These products are widely used in petroleum, chemical, metallurgy, textile, mechanical and electrical, light industry and pharmaceutical industries in the heating, drying, condensation and cooling equipments.

Applications and characteristics

Working temperature  $\leq 280^{\circ}\text{C}$

working pressure  $\leq 32\text{MPa}$

High heat transfer performance, same with KL type (Knurled "L"). Good fins stiffness, against deformation high atmospheric corrosion resistance for long term stable usage.

TECHNIFIN TYPE HY“

A smooth core tubes (pipes) is inserted into an aluminum tubes (pipes) and then fins are extrudes out of the aluminum tube. Advantages: Bond of outer and inner tube removes the risk of loss of contact due to thermal stress, fins are more rigid, also available as serrated type TECHNIFIN „HYS“ see below.

TECHNIFIN TYPE HYS“

As per type „HY“, but fins are serrated. Advantages: Higher heat transfer coefficient, for same pressure drop compared with „HY“ fin.

Magvant



# Fin tubes, Equipments

## Studded tubes

### **Magvant HEAT TRANSFER ELEMENTS: STUDED TUBES**

studded tubes (finned tubes)(TECHNISTUD)

Fields of Application:

Furnaces, Chemical Petrochemical-Industry, Power stations etc. where liquid media under high pressure are to be heated or cooled.

**Magvant** Advantages: Due to their high rigidity, studded tubes can be used even under extreme temperature and pressure conditions.

**Magvant** Manufacturing Process: Studs are fully automatically welded onto the tubes (pipes) by resistance welding.

Materials: Base tubes (pipes) & Studs Carbon Steel Low Alloy Steel Stainless Steel

Length: Up to 30 meters. If necessary with circumferential weld, 100% x-rayed. If required pressure tested.

Studs: General Stud spacing 1/8" (16mm) = 63 Stud rows per meter

Type of Studs: Cylindrical, elliptical or lens type

**Magvant** Pin tubes (pin fin tubes, pin finned tubes)

Pin finned tubes (fin tubes) is a high thermal efficiency heat transfer finned tubes (fin tubes). Using helically wound copper wire, the external fins are mechanically bonded to the base tubes (pipes) via solder. Pin finned tubes (fin tubes) is suitable for a wide variety of air-blast cooling applications including process liquids and gasses, oil, diesel fuel, high pressure water and steam. Pin fin tubes can be manufactured using a variety of base tubes (pipes) materials including copper, brass, copper/nickel, aluminum/brass, carbon steel and stainless steel.

**Magvant** Wire wound internal turbulators are added to enhance thermal performance for viscous fluids such as oil, and for certain gasses, including compressed air and steam.

**Magvant** As the density of the external fin and internal turbulator are variable, Pin finned tubes (fin tubes) can be readily optimized to suit individual applications. This product is fully integrated into Air Radiators standard range of heat exchanger packages, and is also available as loose tubes.

**Magvant** Pin tubes (pin fin tubes, pin finned tubes) intensified heat-transfer component, as a kind of new type heat-transfer component, owns several main advantages as follows. Firstly, no matter the fume scours away tubes (pipes) bundle broadways or length-ways, all of aciculum form extended surface are scoured by fume turbulent flow broadways and airflow forms steady-state whirlpool and reversed-flow region symmetrical to each other behind column back of needle rib. As thermal boundary layer is constantly destroyed and re-form after destroy, the whole heat-transfer surface boundary layer thins down and then thermal resistance reduces, heat-transfer coefficient enhancing greatly as a consequence. Secondly, as Pin tubes (pin fin tubes, pin finned tubes) is a kind of cantilevered structure, under the impact effect of airflow, needle rib will vibrate, making fume difficult to accumulate on the tube, plus intense turbulent-flow scouring of fume, Pin tubes (pin fin tubes, pin finned tubes) intensified heat-transfer component is endowed with stronger self-cleaning capacity. In addition, owning compact structure, low unit heat-interchange quantity and metal consumption, Pin tubes (pin fin tubes, pin finned tubes) is a kind of recommendable intensified component.



# Fin tubes, Equipments

## H fin tubes

### **Magvant HEAT TRANSFER ELEMENTS: H FIN TUBES**

H fin tubes ( finned tubes ) ( TECHNIFIN TYPES“, Double S“)

**Magvant** Pairs of parallel shaped steel fins are resistance welded to the single pressure tubes (pipes) surface under very carefully controlled conditions. The purpose build welding machine ensures very precise indexing along the entire length of the tubes (pipes) and exact parallel attachment.

#### **Magvant** Double H

A development of the single tubes (pipes) version, the 'Double H' design has the steel fins welded onto two tubes at the same time. For applications with cleaner gases the use of 'Double H' can reduce the number of supports required due to its inherent stiffness.

**Magvant** As a general guide, spacing of tubes (pipes) centers is usually in the range of 2-3 times the tubes (pipes) O/Dia.

- . tubes (pipes) O/Dia. [OD] mm - 31.8 to 57.2
- . tubes (pipes) Length [L] Meters - Up to and including 18 Meters maximum
- . Vertical Centers [V] mm - 65 to 133
- . Horizontal Centers [H] mm - 65 to 178
- . Fin Thickness [t] mm - 2.0, 2.5, 3.0 (certain fin shapes can be 1.5mm thick material)
- . Fin Density [P] mm - Minimum 10mm, i.e. 100 Fins Per Meter (FPM)
- . Fin Shape - Over 75 fin shapes as standard, with new fin shapes continually being developed.

**Magvant** Bespoke fin shapes are produced to suit the design application where feasible.

Base tubes (pipes) Material: Typically Carbon, Cor-ten, Low alloy steels.

Tubes quality / type can be Cold Drawn Seamless [CDS], Hot Finished Seamless [HFS], Electric Resistance Welded [ERW].

Fin Material: Carbon Steel Hot Rolled [HR4], Corrosion resisting steels i.e. Cor-ten.



H fin tubes ( finned tubes )

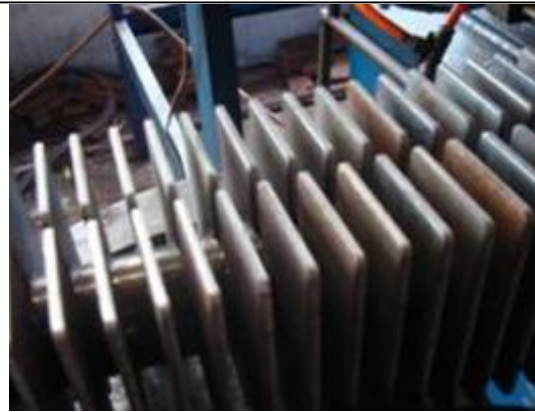

H fin tubes ( finned tubes )

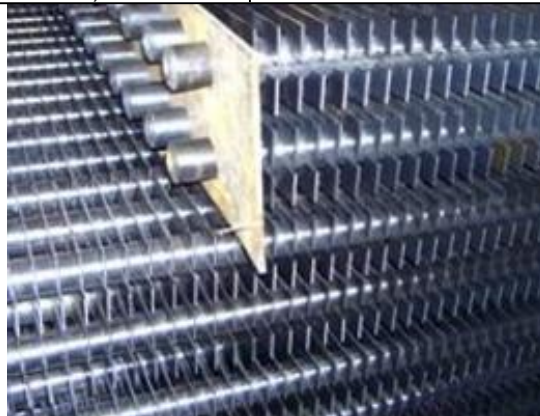

H fin tubes ( finned tubes )

# Fin tubes, Equipments

## Longitudinal fin tubes. spiral slot tubes. corrugated tubes. heat pipes

### Magvant LONGITUDINAL FIN TUBES ( FINNED TUBES )

longitudinal fin tubes ( finned tubes )

longitudinal fin, in the form of a U-shaped fin channel, is resistance welded along the tube's longitudinal axis. longitudinal fin tubes are produced by resistance welding fins in the longitudinal direction along the length of the tube. The fin strip is first formed into a U-shaped channel, such that each leg of the U will form a fin. The channels are cut to the appropriate length and then oriented along the length of the tubes (pipes) and resistance welded in place. The channels are welded in pairs

Tube Sizes:	3/4" O.D. to 12" NPS (12.75" O.D.)
Fin Heights:	.21" to 1 1/2"
Fin Thicknesses:	20 ga. (.035") to 18 ga. (.050")
Material:	Brass, Mild steel, stainless steel, and nickel alloys.



### Magvant HEAT TRANSFER ELEMENTS: LOW FIN TUBES

Magvant low fin tubes : TECHNIFIN TYPE N"

The fins are rolled out of the wall of the plain tube. Tube and fin are consisting of one piece. Advantages: Excellent heattransfer, good bending properties, wide range of material can be used.

copper low fin tubes ( finned tubes ), normal materials:

ASTM B 75 / B 111 No. 12200, ASTM B 75 / B 111 No. 142, ASTM B 111 No. 44300, ASTM B 111 No. 68700, ASTM B 111 No. 608, ASTM B 111 No. 70600, ASTM B 111 No. 71500

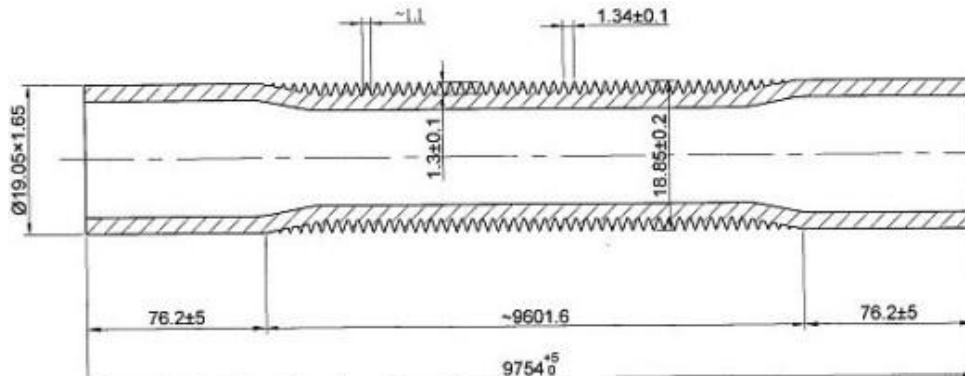

Drawing for reference

Magvant Spiral slot tubes, corrugated tubes



heat pipes



# Fin tubes, Equipments

## Oval fin tubes

### Magvant HEAT TRANSFER ELEMENTS: OVAL FIN TUBES

Oval fin tubes ( finned tubes ) is by setting up rectangular or square-shaped fins over Oval tube. This Finned tubes (pipes) maximizes the performance of Heat Exchangers and minimizes the loss of heat transfer and pressure. This drawings comes from a guest/customer only for share with you.

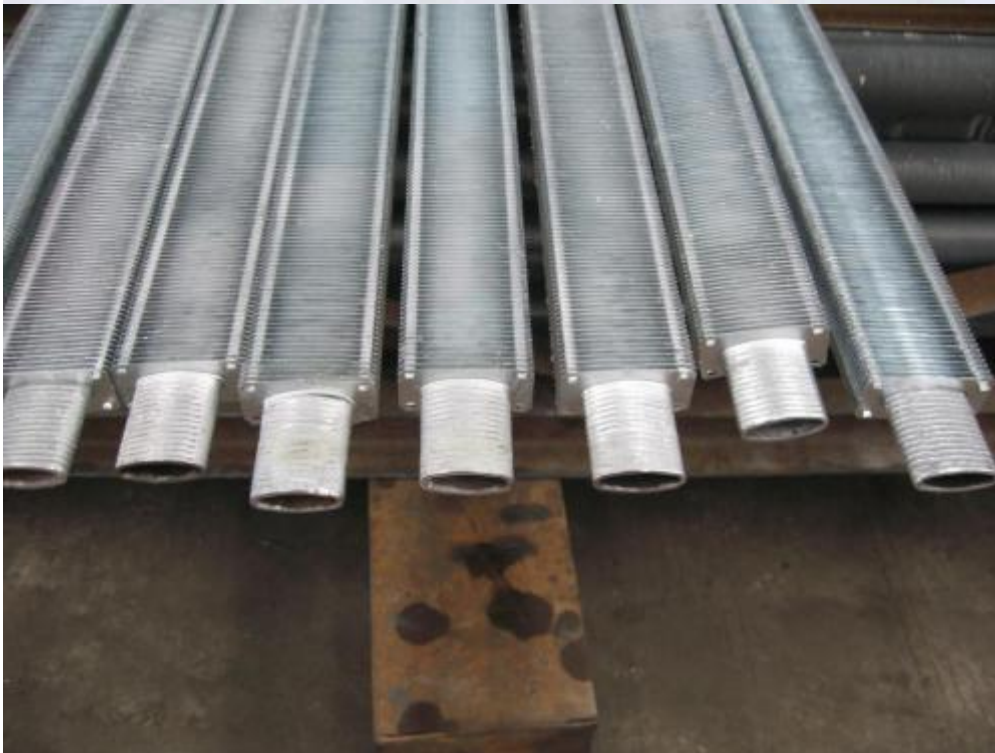
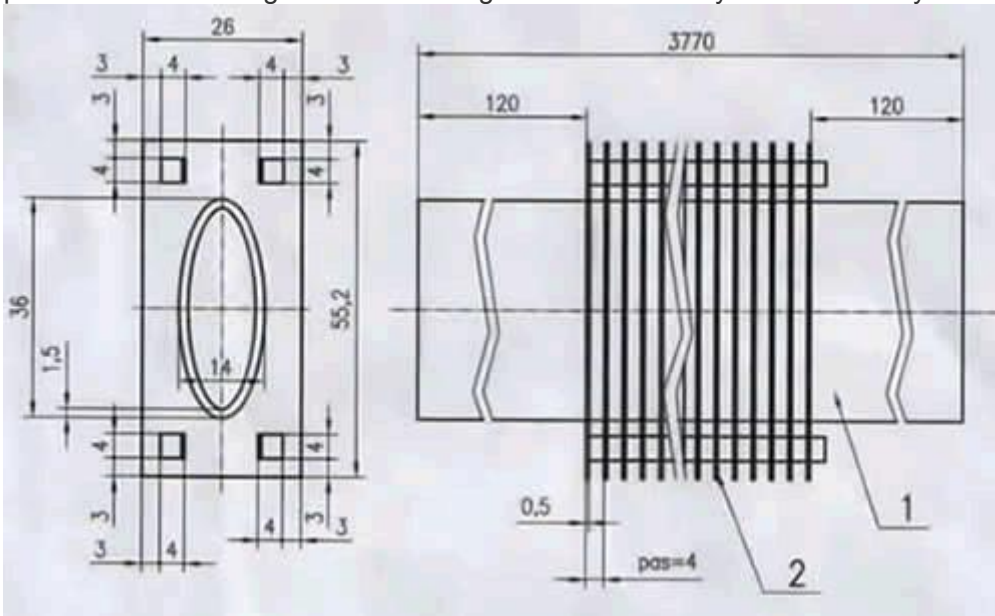

# Fin tubes, Equipments

## Tube finning machines

### Magvant TUBE FINNING MACHINES

HF-200KW (II) / 400KW High frequency Welded Spiral fin tubes Machine

Tube finning machine for L, LL, KL, G fin tubes ( finned tubes ), Laser welded tube.

Download catalogue 



tubes (pipes) finning machines



tubes (pipes) finning machines



tubes (pipes) finning machines



tubes (pipes) finning machines



## Chemical composition for Carbon steel / Alloy tubes

Chemical composition %

标准 Standard	牌号 Grade	C	Si	Mn	P	S	Cr	Mo	V
GB3087	10	0.07 ~ 0.13	0.17 ~ 0.37	0.35 ~ 0.65	≤0.030	≤0.030	≤0.15	-	-
	20	0.17 ~ 0.23	0.17 ~ 0.37	0.35 ~ 0.65	≤0.030	≤0.030	≤0.25	-	-
GB5310	20G	0.17 ~ 0.24	0.17 ~ 0.37	0.35 ~ 0.65	≤0.030	≤0.030	-	-	-
	20MnG	0.17 ~ 0.25	0.17 ~ 0.37	0.70 ~ 1.00	≤0.030	≤0.030	-	-	-
	25MnG	0.22 ~ 0.30	0.17 ~ 0.37	0.70 ~ 1.00	≤0.030	≤0.030	-	-	-
	15CrMo	0.12 ~ 0.18	0.17 ~ 0.37	0.40 ~ 0.70	≤0.030	≤0.030	0.80 ~ 1.10	0.40 ~ 0.55	-
	12Cr2MoG	0.08 ~ 0.15	≤0.50	0.40 ~ 0.70	≤0.030	≤0.030	2.00 ~ 2.50	0.90 ~ 1.20	-
	12Cr1MoG	0.08 ~ 0.15	0.17 ~ 0.37	0.40 ~ 0.70	≤0.030	≤0.030	0.90 ~ 1.20	0.25 ~ 0.35	0.15 ~ 0.30
ASME SA106	SA106B	≤0.30	≥0.1	0.29 ~ 1.06	≤0.035	≤0.035	-	-	-
	SA106C	≤0.35	≥0.1	0.29 ~ 1.06	≤0.035	≤0.035	-	-	-
ASME SA333	SA333 I 级	≤0.30	≥0.1	0.40 ~ 1.06	≤0.025	≤0.025	-	-	-
	SA333 VI 级	≤0.30	≥0.1	0.29 ~ 1.06	≤0.025	≤0.025	-	-	-
ASME SA335	SA335 P11	0.05 ~ 0.15	0.50 ~ 1.0	0.30 ~ 0.60	≤0.025	≤0.025	1.00 ~ 1.50	0.44 ~ 0.65	-
	SA335 P12	0.05 ~ 0.15	≤0.50	0.30 ~ 0.61	≤0.025	≤0.025	0.80 ~ 1.25	0.44 ~ 0.65	-
	SA335 P22	0.05 ~ 0.15	≤0.50	0.30 ~ 0.60	≤0.025	≤0.025	1.90 ~ 2.60	0.87 ~ 1.13	-
	SA335 P5	≤0.15	≤0.50	0.30 ~ 0.60	≤0.025	≤0.025	4.00 ~ 6.00	0.45 ~ 0.65	-
DIN 17175	ST45.8/III	≤0.21	0.10 ~ 0.35	0.40 ~ 1.20	≤0.040	≤0.040	-	-	-
	15Mo3	0.12 ~ 0.20	0.10 ~ 0.35	0.40 ~ 0.80	≤0.035	≤0.035	-	0.25 ~ 0.35	-
	13CrMo44	0.10 ~ 0.18	0.10 ~ 0.35	0.40 ~ 0.70	≤0.035	≤0.035	0.70 ~ 1.10	0.45 ~ 0.65	-
	10CrMo910	0.08 ~ 0.15	≤0.50	0.40 ~ 0.70	≤0.035	≤0.035	2.00 ~ 2.50	0.90 ~ 1.20	-
ASME SA210	SA210A-1	≤0.27	≥0.10	≤0.93	≤0.035	≤0.035	-	-	-
	SA210C	≤0.35	≥0.10	0.29 ~ 1.06	≤0.035	≤0.035	-	-	-
ASME SA213	SA213 T11	0.05 ~ 0.15	0.50 ~ 1.0	0.30 ~ 0.60	≤0.025	≤0.025	1.00 ~ 1.50	0.44 ~ 0.65	-
	SA213 T12	0.05 ~ 0.15	≤0.50	0.30 ~ 0.61	≤0.025	≤0.025	0.80 ~ 1.25	0.44 ~ 0.65	-
	SA213 T22	0.05 ~ 0.15	≤0.50	0.30 ~ 0.60	≤0.025	≤0.025	1.90 ~ 2.60	0.87 ~ 1.13	-
ASME SA192M	SA192	0.06 ~ 0.18	≤0.25	0.27 ~ 0.63	≤0.035	≤0.035	-	-	-
JIS G 3461	STB 340	≤0.18	≤0.35	0.30 ~ 0.60	≤0.035	≤0.035	-	-	-
	STB 410	≤0.32	≤0.35	0.30 ~ 0.80	≤0.035	≤0.035	-	-	-
EN 10216-1	P195TR1	≤0.13	≤0.35	≤0.70	≤0.025	≤0.020	≤0.3	≤0.08	≤0.02
EN 10216-1	P235TR2	≤0.16	≤0.35	≤1.20	≤0.025	≤0.020	≤0.3	≤0.08	≤0.02

注 1: EN 标准残余元素 Nb≤0.01%, Ti≤0.04%, Ni ≤0.30%, Cu≤0.30% 总量≤0.70%

Note1: EN residual element Nb≤0.01%, Ti≤0.04%, Ni ≤0.30%, Cu≤0.30% total≤0.70%

注 2: 经协商, 也可供应其他牌号的钢管

Note2: Other grade can also be provided according to agreements with customers.

ASTM A179/A179M ASME SA179/SA179M: C 0,06~0,18%; Mn 0,27~0,63%; P max 0,035% ;S max. 0,035%;

# Stainless Steels

Austenitic, ferritic and Martensitic Stainless steel

## Chemical Composition

Grade		Chemical compositions %										
		C	Cr	Ni	Mn	P	S	Mo	Si	Cu	N	Others
201	1Cr17Mn6Ni5N	≤0.15	16.00-18.00	3.50-5.50	5.50-7.50	≤0.060	≤0.030	-	≤1.00	-	≤0.25	-
201L	03Cr17Mn6Ni5N	≤0.030	16.00-18.00	3.50-5.50	5.50-7.50	≤0.060	≤0.030	-	≤1.00	-	≤0.25	-
202	1Cr18Mn8Ni5N	≤0.15	17.00-19.00	4.00-6.00	7.50-10.00	≤0.060	≤0.030	-	≤1.00	-	≤0.25	-
204	03Cr16Mn8Ni2N	≤0.030	15.00-17.00	1.50-3.50	7.00-9.00	-	-	-	-	-	0.15-0.30	-
China	1Cr18Mn10Ni5Mo3N	≤0.10	17.00-19.00	4.00-6.00	8.50-12.00	-	-	2.80-3.50	-	-	0.20-0.30	-
Russian	2Cr13Mn9Ni4	0.15-0.25	12.00-14.00	3.70-5.00	8.00-10.00	-	-	-	-	-	-	-
China	2Cr15Mn15Ni2N	0.15-0.25	14.00-16.00	1.50-3.00	14.00-16.00	-	-	-	-	-	0.15-0.30	-
	1Cr18Mn10Ni5Mo3N	≤0.15	17.00-19.00	4.00-6.00	8.50-12.00	≤0.060	≤0.030	2.8-3.5	≤1.00	-	0.20-0.30	-
301	1Cr17Ni7	≤0.15	16.00-18.00	6.00-8.00	≤2.00	≤0.065	≤0.030	-	≤1.00	-	-	-
302	1Cr18Ni9	≤0.15	17.00-19.00	8.00-10.00	≤2.00	≤0.035	≤0.030	-	≤1.00	-	-	-
303	Y1Cr18Ni9	≤0.15	17.00-19.00	8.00-10.00	≤2.00	≤0.20	≤0.030	-	≤1.00	-	-	-
303se	Y1Cr18Ni9Se	≤0.15	17.00-19.00	8.00-10.00	≤2.00	≤0.20	≤0.030	-	≤1.00	-	-	Se≥0.15
304	0Cr18Ni9	≤0.07	17.00-19.00	8.00-10.00	≤2.00	≤0.035	≤0.030	-	≤1.00	-	-	-
304L	00Cr19Ni10	≤0.030	18.00-20.00	8.00-10.00	≤2.00	≤0.035	≤0.030	-	≤1.00	-	-	-
304N1	0Cr19Ni9N	≤0.08	18.00-20.00	7.00-10.50	≤2.00	≤0.035	≤0.030	-	≤1.00	-	0.10-0.25	-
304N2	0Cr18Ni10NbN	≤0.08	18.00-20.00	7.50-10.50	≤2.00	≤0.035	≤0.030	-	≤1.00	-	0.15-0.30	Nb≤0.15
304LN	00Cr18Ni10N	≤0.030	17.00-19.00	8.50-11.50	≤2.00	≤0.035	≤0.030	-	≤1.00	-	0.12-0.22	-
305	1Cr18Ni12	≤0.12	17.00-19.00	10.50-13.00	≤2.00	≤0.035	≤0.030	-	≤1.00	-	-	-
309S	0Cr23Ni13	≤0.08	22.00-24.00	12.00-15.00	≤2.00	≤0.035	≤0.030	-	≤1.00	-	-	-
310S	0Cr25Ni20	≤0.08	24.00-26.00	19.00-22.00	≤2.00	≤0.035	≤0.030	-	≤1.00	-	-	-
316	0Cr17Ni12Mo2	≤0.08	16.00-18.50	10.00-14.00	≤2.00	≤0.035	≤0.030	2.00-3.00	≤1.00	-	-	-
	1Cr18Ni12Mo2Ti6	≤0.12	16.00-19.00	11.00-14.00	≤2.00	≤0.035	≤0.030	1.80-2.50	≤1.00	-	-	Ti5(C%-0.02)~0.08
	0Cr18Ni12Mo2Ti	≤0.08	16.00-19.00	11.00-14.00	≤2.00	≤0.035	≤0.030	1.80-2.50	≤1.00	-	-	Ti5°C%-0.70
316L	00Cr17Ni14Mo2	≤0.030	16.00-18.00	12.00-15.00	≤2.00	≤0.035	≤0.030	2.00-3.00	≤1.00	-	-	-
316N	0Cr17Ni12Mo2N	≤0.08	16.00-18.00	10.00-14.00	≤2.00	≤0.035	≤0.030	2.00-3.00	≤1.00	-	0.10-0.22	-
316N	00Cr17Ni13Mo2N	≤0.030	16.00-18.50	10.50-14.50	≤2.00	≤0.035	≤0.030	2.00-3.00	≤1.00	-	0.12-0.22	-
316J1	0Cr18Ni12Mo2Cu2	≤0.08	17.00-19.00	10.00-14.50	≤2.00	≤0.035	≤0.030	1.20-2.75	≤1.00	1.00-2.50	-	-
316J1L	00Cr18Ni14Mo2Cu2	≤0.030	17.00-19.00	12.00-16.00	≤2.00	≤0.035	≤0.030	1.20-2.75	≤1.00	1.00-2.50	-	-
317	0Cr19Ni13Mo3	≤0.12	18.00-20.00	11.00-15.00	≤2.00	≤0.035	≤0.030	3.00-4.00	≤1.00	-	-	-
317L	00Cr19Ni13Mo3	≤0.08	18.00-20.00	11.00-15.00	≤2.00	≤0.035	≤0.030	3.00-4.00	≤1.00	-	-	-
	1Cr18Ni12Mo3Ti6	≤0.12	16.00-19.00	11.00-14.00	≤2.00	≤0.035	≤0.030	2.50-3.50	≤1.00	-	-	Ti5(C%-0.02)~0.08
	0Cr18Ni12Mo3Ti	≤0.08	16.00-19.00	11.00-14.00	≤2.00	≤0.035	≤0.030	2.50-3.50	≤1.00	-	-	Ti5°C%-0.70
317J1	0Cr18Ni16Mo5	≤0.040	16.00-19.00	15.00-17.00	≤2.00	≤0.035	≤0.030	4.00-6.00	≤1.00	-	-	-
321	1Cr18Ni9Ti6	≤0.12	17.00-19.00	8.00-11.00	≤2.00	≤0.035	≤0.030	-	≤1.00	-	-	Ti5(C%-0.02)~0.08
	0Cr18Ni10Ti	≤0.08	17.00-19.00	9.00-12.00	≤2.00	≤0.035	≤0.030	-	≤1.00	-	-	Ti≥5°C%
347	0Cr18Ni11Nb	≤0.08	17.00-19.00	9.00-13.00	≤2.00	≤0.035	≤0.030	-	≤1.00	-	-	Nb≥10°C%
XM7	0Cr18Ni9Cu3	≤0.08	17.00-19.00	8.50-10.50	≤2.00	≤0.035	≤0.030	-	≤1.00	3.00-4.00	-	-
XM15J1	0Cr18Ni13Si4	≤0.08	15.00-20.00	11.50-15.00	≤2.00	≤0.035	≤0.030	-	3.00-5.00	-	-	2)
329J1	0Cr26Ni5Mo2	≤0.08	23.00-28.00	3.00-6.00	≤1.50	≤0.035	≤0.030	1.00-3.00	≤1.00	-	-	2)
	1Cr18Ni11Si4AlTi	0.10-0.18	17.50-19.50	10.-120.	≤0.80	≤0.035	≤0.030	-	3.40-4.00	-	-	Al 0.10-0.30 ; Ti 0.40-0.70
	00Cr18Ni5MoSi2	≤0.030	18.00-19.50	4.50-5.50	1.00-2.00	≤0.035	≤0.030	2.50-3.00	1.30-2.00	-	-	-

# Chemical composition for Carbon steel /Alloy tubes

## Chemical Composition

Grade		Chemical compositions %										
		C	Cr	Ni	Mn	P	S	Mo	Si	Cu	N	其它
405	0Cr13Al	≤0.08	11.50-14.50		≤1.00	≤0.035	≤0.030	-	≤1.00	-	-	Al 0.10-0.30
410L	00Cr12	≤0.030	11.00-13.00		≤1.00	≤0.035	≤0.030	-	≤1.00	-	-	-
430	1Cr17	≤0.12	16.00-18.00		≤1.25	≤0.035	≤0.030	-	≤0.75	-	-	-
430F	Y1Cr17	≤0.12	16.00-18.00		≤1.00	≤0.035	≥0.15		≤1.00	-	-	-
434	1Cr17Mo	≤0.12	16.00-18.00		≤1.00	≤0.035	≤0.030	0.75-1.25	≤1.00	-	-	-
447J1	00Cr30Mo2	≤0.010	28.50-32.00		≤0.40	≤0.035	≤0.030	1.50-2.50	≤0.40	-	≤0.015	-
XM27	00Cr27Mo	≤0.010	25.00-27.50		≤0.40	≤0.035	≤0.030	0.75-1.50	≤0.40	-	≤0.015	-
403	1Cr12	≤0.15	11.50-13.00		≤1.00	≤0.035	≤0.030	-	≤0.50	-	-	-
410	1Cr13	≤0.15	11.50-13.50		≤1.00	≤0.035	≤0.030	-	≤1.00	-	-	-
405	0Cr13	≤0.08	11.50-13.50		≤1.00	≤0.035	≤0.030	-	≤1.00	-	-	-
416	Y1Cr13	≤0.15	12.00-14.00		≤1.25	≤0.035	≥0.15		≤1.00	-	-	-
410J1	1Cr13Mo	≤0.08-0.18	11.50-14.00		≤1.00	≤0.035	≤0.030	0.30-0.60	≤0.60	-	-	-
420J1	2Cr13	0.16-0.25	12.00-14.00		≤1.00	≤0.035	≤0.030	-	≤1.00	-	-	-
420J2	3Cr13	0.26-0.35	12.00-14.00		≤1.00	≤0.035	≤0.030	-	≤1.00	-	-	-
420F	Y3Cr13	0.26-0.40	12.00-14.00		≤1.25	≤0.035	≥0.15		≤1.00	-	-	-
	3Cr13Mo	0.28-0.35	12.00-14.00		≤1.00	≤0.035	≤0.030	0.50-1.00	≤0.80	-	-	-
	4Cr13	0.36-0.45	12.00-14.00		≤0.80	≤0.035	≤0.030	-	≤0.60	-	-	-
431	1Cr17Ni2	0.11-0.17	16.00-18.00	1.50-2.50	≤0.80	≤0.035	≤0.030	-	≤0.80	-	-	-
440A	7Cr17	0.60-0.75	16.00-18.00		≤1.00	≤0.035	≤0.030		≤1.00	-	-	-
440B	8Cr17	0.75-0.95	16.00-18.00		≤1.00	≤0.035	≤0.030		≤1.00	-	-	-
	9Cr18	0.90-1.00	17.00-19.00		≤0.80	≤0.035	≤0.030		≤0.80	-	-	-
440C	11Cr17	0.95-1.20	16.00-18.00		≤1.00	≤0.035	≤0.030		≤1.00	-	-	-
440F	Y11Cr17	0.95-1.20	16.00-18.00		≤1.25	≤0.035	≥0.15		≤1.00	-	-	-
	9Cr18Mo	0.95-1.10	16.00-18.00		≤0.80	≤0.035	≤0.030	0.40-0.70	≤0.80	-	-	-
	9Cr18MoV	0.85-0.95	17.00-19.00		≤0.80	≤0.035	≤0.030	1.00-1.30	≤0.80	-	-	V0.07-0.12
630	0Cr17Ni4Cu4Nb	≤0.07	15.50-17.50	6.50-7.50	≤1.00	≤0.035	≤0.030	-	≤1.00	3.00-5.00	-	Nb 0.15-0.45
631	0Cr17Ni7Al	≤0.09	16.00-18.00	6.50-7.50	≤1.00	≤0.035	≤0.030	-	≤1.00	≤0.50	-	Al 0.75-1.50
632	0Cr15Ni7Mo2Al	≤0.09	14.00-16.00	6.50-7.50	≤1.00	≤0.035	≤0.030	2.00-3.00	≤1.00	-	-	Al 0.75-1.50

## Super-Duplex Stainless Steel

### Ferritic and Martensitic Stainless Steel Tubes

Material Standard ASTM A 789; Manufacturing Process Seamless or welded

Called Duplex because of its mixed micro-structure with about equal proportions of ferrite and austenite, Duplex stainless steels are a family of grades, which range in corrosion performance depending on their alloy content. The term "Super-Duplex" was first used in the 1980's to denote highly alloyed, high-performance Duplex steel with a pitting resistance equivalent of >40 (based on Cr% + 3.3 Mo% + 16N%). With its high level of chromium, Super-Duplex steel provides outstanding resistance to acids, acid chlorides, caustic solutions and other environments in the chemical / petrochemical, pulp and paper industries, often replacing 300 series stainless steel, high nickel superaustenitic steels and nickel-based alloys. The chemical composition based on high contents of chromium, nickel and molybdenum improves intergranular and pitting corrosion resistance. Additions of nitrogen promote structural hardening by interstitial solid solution mechanism, which raises the yield strength and ultimate strength values without impairing toughness. Moreover, the two-phase microstructure guarantees higher resistance to pitting and stress corrosion cracking in comparison with conventional stainless steels.

### Composition of Duplex Stainless Steels <sup>a</sup>

The Table lists the duplex stainless steel covered in ASTM specifications for plate, sheet and bar products.

UNS Number	Type <sup>b</sup>	C	Mn	P	S	Si	Cr	Ni	Mo	N	Cu	Other
S31200	...	0.030	2.00	0.045	0.030	1.00	24.0-26.0	5.5-6.5	1.20-2.00	0.14-0.20	...	...
S31260	...	0.03	1.00	0.030	0.030	0.75	24.0-26.0	5.5-7.5	2.5-3.5	0.10-0.20	0.20-0.80	W0.10-0.20
S31803	...	0.030	2.00	0.030	0.020	1.00	21.0-23.0	4.5-6.5	2.5-3.5	0.08-0.20	...	
S32001	...	0.030	4.0-6.0	0.040	0.030	1.00	22.0-23.0	1.00-3.00	0.60	0.05-0.17	1.00	
S32205	2205	0.030	2.00	0.030	0.020	1.00	19.5-21.5	4.5-6.5	3.0-3.5	0.14-0.20	...	
S32304	2304	0.030	2.50	0.040	0.030	1.00	21.5-24.5	3.0-5.5	0.05-0.60	0.05-0.20	0.05-0.60	
S32520	...	0.030	1.50	0.035	0.020	0.80	24.0-26.0	5.5-8.0	3.0-4.0	0.20-0.35	0.50-2.00	
S32550	255	0.04	1.50	0.040	0.030	1.00	24.0-27.0	4.5-6.5	2.9-3.9	0.10-0.25	1.5-2.5	
S32750	2507	0.030	1.20	0.035	0.020	0.80	24.0-26.0	6.0-8.0	3.0-5.0	0.24-0.32	0.50	
S32760	...	0.030	1.00	0.030	0.010	1.00	24.0-26.0	6.0-8.0	3.0-4.0	0.20-0.30	0.50-1.00	c
S32900	329 <sup>d</sup>	0.06	1.00	0.040	0.030	0.75	23.0-28.0	2.5-5.0	1.0-2.0	...	...	
S32950	...	0.03	2.00	0.035								

a ... Weight percent, maximum unless otherwise noted.

b ... Unless otherwise indicated, a common name, not a trademark, widely used, not associated with any one producer, as listed in ASTM A240.

c ... W 0.50-1.00; Cr+3.3 Mo + 16N=40 min

d ... AISI designation

# Line Pipes for Low Temperature Service

ASTM-A333/Seamless and Welded

Element	Composition %								
	Grade 1	Grade 3	Grade 4	Grade 6	Grade 7	Grade 8	Grade 9	Grade 10	Grade 11
Carbon, max.	0.30	0.19	0.12	0.30	0.19	0.13	0.20	0.20	0.10
Manganese	0.40-1.06	0.31-0.64	0.50-1.05	0.29-1.06	0.90 max	0.90 max	0.40-1.06	1.15-1.50	0.60 max
Phosphorus, max	0.025	0.025	0.025	0.025	0.025	0.025	0.025	0.035	0.025
Sulfur, max	0.025	0.025	0.025	0.025	0.025	0.025	0.025	0.015	0.025
Silicon	-	0.18-0.37	0.08-0.37	0.10 min	0.13-0.32	0.13-0.32	-	0.10-0.35	0.35 max
Nickel	-	3.18-3.82	0.47-0.98	-	2.03-2.57	8.40-9.60	1.60-2.24	0.25 max	35.0-37.0
Chromium	-	-	0.44-1.01	-	-	-	-	0.15 max	0.50 max
Copper	-	-	0.40-0.75	-	-	-	0.75-1.25	0.15 max	-
Aluminium	-	-	0.04-0.30	-	-	-	-	0.06 max	-
Vanadium, max	-	-	-	-	-	-	-	0.12	-
Columbium, max	-	-	-	-	-	-	-	0.05	-
Molybdenum, max	-	-	-	-	-	-	-	0.05	0.50 max
Cobalt	-	-	-	-	-	-	-	-	0.50 max

	Grade 1		Grade 3		Grade 4		Grade 6		Grade 7		Grade 8		Grade 9		Grade 10		Grade 11	
	psi	MPa	psi	MPa	psi	MPa	psi	MPa	psi	MPa	psi	MPa	psi	MPa	psi	MPa	psi	Mpa
Tensile strength, min	55 000	380	65 000	450	60 000	415	60 000	415	65 000	450	100 000	690	63 000	435	80 000	550	65 000	450
Yield strength, min	30 000	205	35 000	240	35 000	240	35 000	240	35 000	240	75 000	515	46 000	315	65 000	450	35 000	240
	Longi- tudinal	Trans- verse	Longi- tudinal	Trans- verse	Longi- tudinal	Trans- verse	Longi- tudinal	Trans- verse	Longi- tudinal	Trans- verse	Longi- tudinal	Trans- verse	Longi- tudinal	Trans- verse	Longi- tudinal	Trans- verse	Longi- tudinal	
Elongation in 2 in. or 50 mm, (or 4D), min. % Basic minimum elongation for walls 5/16 in. (8mm) and over in thickness, strip tests, and for all small sizes tested in full section	35	25	30	20	30	16.5	30	16.5	30	22	22	-	28	-	22	-	18A	
When standard round 2-in. or 50-mm gage-length or proportionally smaller size test specimen with the gage length equal to 4D (4 times the diameter) is used	28	20	22	14	22	12	22	12	22	14	16	-	-	-	16	-	-	
For strip tests, a deduction for each 1/32 in. (0.8 mm) decrease in wall thickness below 5/16 in. (8 mm) from the basic minimum elongation of the following percentage	1.75	1.25	1.50	1.00	1.50	1.00	1.50	1.00	1.50	1.00	1.25	-	1.50	-	1.25	-	-	

# Line Pipes Alloy Steel

ASTM-A335/Seamless

## Chemical Composition

Grade	UNS Designation	Composition, %							
		Carbon	Manganese max.	Phosphorus	Sulfur max	Silicon	Chromium	Molybdenum	Others
P1	K11522	0.10-0.20	0.30-0.80	0.025	0.025	0.10-0.50	—	0.44-0.65	—
P2	K11547	0.10-0.20	0.30-0.61	0.025	0.025	0.10-0.30	0.50-0.81	0.44-0.65	—
P5	K41545	0.15 max	0.30-0.60	0.025	0.025	0.50 max	4.00-6.00	0.45-0.65	—
P5b	K51545	0.15 max	0.30-0.60	0.025	0.025	1.00-2.00	4.00-6.00	0.45-0.65	—
P5c	K41245	0.12 max	0.30-0.60	0.025	0.025	0.50 max	4.00-6.00	0.45-0.65	—
P9	S50400	0.15 max	0.30-0.60	0.025	0.025	0.25-1.00	8.00-10.00	0.90-1.10	—
P11	K11597	0.05-0.15	0.30-0.60	0.025	0.025	0.50-1.00	1.00-1.50	0.44-0.65	—
P12	K11562	0.05-0.15	0.30-0.61	0.025	0.025	0.50 max	0.80-1.25	0.44-0.65	—
P15	K11578	0.05-0.15	0.30-0.60	0.025	0.025	1.15-1.65	—	0.44-0.65	—
P21	K31545	0.05-0.15	0.30-0.60	0.025	0.025	0.50 max	2.65-3.35	0.80-1.06	—
P22	K21590	0.05-0.15	0.30-0.60	0.025	0.025	0.50 max	1.90-2.60	0.87-1.13	—
P91	K91560	0.08-0.12	0.30-0.60	0.020	0.010	0.20-0.50	8.00-9.50	0.85-1.05	V0.18-0.25 N 0.030-0.070 Ni 0.40 max Al 0.04 max Cb 0.06-0.10
P92	K92460	0.07-0.13	0.30-0.60	0.020	0.010	0.50 max	8.50-9.50	0.30-0.60	V0.15-0.25 N 0.03-0.07 Ni 0.40 max Al 0.04 max Cb 0.04-0.09 W 1.5-2.00 B 0.001-0.006
P122	K92930	0.07-0.14	0.70 max	0.020	0.010	0.50 max	10.00-12.50	0.25-0.60	V0.15-0.30 W 1.50-2.50 Cu 0.30-1.70 Cb 0.04-0.10 B 0.0005-0.005 N 0.040-0.100 Ni 0.50 max Al 0.040 max

## Tensile Requirements

Identification Symbol	P1, P2	P12	P91	P92	P122	All Others
Tensile strength, min:						
ksi	55	60	85	90	90	60
MPa	380	415	585	620	620	415
Yield strength, min:						
ksi	30	32	60	64	58	30
MPa	205	220	415	440	400	205

## Elongation requirements

	All grades except P91 and P92		P91 and P122	
	Longitudinal	Transverse	Longitudinal	Transverse
Elongation in 2 in. or 50 mm, (or 4D), min, %:				
Basic minimum elongation for wall 5/16 in. (8 mm) and over in thickness, strip tests, and for all small sizes tested in full section.	30	20	20	-
When standard round 2-in. proportionally smaller size specimen with the gage length equal to 4D (4 times the diameter) is used.	22	14	20	13
For strip tests a deduction for each 1/32-in. (0.8 mm) decrease in wall thickness below in. (8 mm) from the basic minimum elongation of, the following percentage points shall be made	1.50	1.00	1.00	-

# Line Pipes Alloy Steel

ASTM-A106 / Seamless

## Chemical Composition

Composition %			
	Grade A	Grade B	Grade C
Carbon, max	0.25	0.30	0.35
Manganese	0.27-0.93	0.29-1.06	0.29-1.06
Phosphorus, max	0.035	0.035	0.035
Sulfur, max	0.035	0.035	0.035
Silicon, min	0.10	0.10	0.10
Chrome, max	0.40	0.40	0.40
Copper, max	0.40	0.40	0.40
Molybdenum, max	0.15	0.15	0.15
Nickel, max	0.40	0.40	0.40
Vanadium, max	0.08	0.08	0.08

	Grade A (Explanatory Note 2)		Grade B		Grade C	
Tensile strength, min, psi (MPa)	48 000 (330)		60 000 (415)		70 000 (485)	
Yield strength, min, psi (MPa)	30 000 (205)		35 000 (240)		40 000 (275)	
	Longitudinal	Transverse	Longitudinal	Transvers	Longitudinal	Transvers
Elongation in 2 in. or 50 mm, min, %:	35	25	30	16.5	30	16.5
Basic minimum elongation transverse strip tests, and for all small sizes tested in full section	28	20	22	12	20	12
When standard round 2-in. or 50-mm gage length test specimen is used						
For longitudinal strip tests						
For transverse strip tests, a deduction for each 1/32-in. (0.8 mm) decrease in wall thickness below 5/16in. (7.9 mm) from the basic minimum elongation of the following percentage shall be made		1.25 <sup>c</sup>		1.00 <sup>c</sup>		1.00 <sup>c</sup>



# Furnace Tubes for Refinery Service

ASTM-A 161 (94) • SEAMLESS

## Chemical Composition

Element	Composition. %	
	Low Carbon Steel Tubes	Grade T1
Carbon	0.10-0.20	0.10-0.20
Manganese	0.30-0.80	0.30-0.80
Phosphorus. max.	0.035	0.025
Sulfur. max.	0.035	0.025
Silicon	0.025 max	0.10-0.50
Molybdenum	...	0.44-0.65



## Tensile Requirements

	Low Carbon Steel Tubes	Grade T1
Tensile strength. min. ksi (MPa)	47 (324)	55 (379)
Yield strength. min. ksi (MPa)	26 (179)	30 (207)
Elongation in 2 in. or 50 mm (or 4D) min%		
Basic minimum elongation for walls 5/16 in. (7.9 mm) and over in thickness	35	30
When standard round tension test specimen with 2-in. or 50-mm gage length or smaller proportionally sized specimen with the gage length equal to 4D (4 times the diameter) is used	28	22
For longitudinal strip tests, a deduction shall be made for each 1/32-in. (0.80mm) decrease in wall thickness below 3/16 in.(7.9mm) from the basic minimum. elongation of the following percentage	1.75 <sup>A</sup>	1.50 <sup>A</sup>

## Minimum Elongation Values

Wall thickness in. (mm)	Elongation in 2 in. or 50 mm. min. % <sup>A</sup>	
	Low Carbon Steel Tubes	Grade T1
5/16 (0.312) 7.94	35	30
9/32 (0.281) 7.14	33	28
1/4 (0.250) 6.35	32	27
7/32 (0.219) 5.56	30	26
3/16 (0.188) 4.76	28	24
5/32 (0.156) 3.97	26	22
1/8 (0.125) 3.18	25	21
3/32 (0.094) 2.38	23	20
1/16 (0.062) 1.59	21	18



	Brinell Hardness Number	
	Low Carbon Steel Tubes	Grade T1
Hot-rolled tubes	137	150
Cold-finished tubes	125	137



# Furnace Tubes for Refinery Service

ASTM-A200 (94)

## Chemical Composition

Grade	Composition, %							
	Carbon	Manganese	Phosphorus max	Sulfur, max	Silicon	Chromium	Molybdenum	Others
T4	0.05-0.15 max	0.30-0.60	0.025	0.025	0.50-1.00	2.15-2.85	0.44-0.65	—
T5	0.15 max	0.30-0.60	0.025	0.025	0.50 max	4.00-6.00	0.45-0.65	—
T7	0.15 max	0.30-0.60	0.025	0.025	0.50-1.00	6.00-8.00	0.45-0.65	—
T9	0.15 max	0.30-0.60	0.025	0.025	0.25-1.00	8.00-10.00	0.90-1.10	—
T91	0.08-0.12	0.30-0.60	0.020	0.010	0.20-0.50	8.00-9.00	0.85-1.05	Ni-0.40max V-0.8-0.25 Cb-0.06-0.10 N-0.030-0.070 Al-0.04 max
T11	0.05 min-0.15 max	0.30-0.60	0.025	0.025	0.50-1.00	1.00-1.50	0.44-0.65	—
T21	0.05 min-0.15 max	0.30-0.30	0.025	0.025	0.50 max	2.65-3.35	0.80-1.06	—
T22	0.05 min-0.15 max	0.30-0.60	0.025	0.025	0.50 max	1.90-2.60	0.87-1.13	—

## Tensile Requirements

	All grades except T91	Grade T91
Tensile strength, min. lsi (MPa)	60 (414)	85 (585)
Yield strength, min. ksi (MPa)	25 (172)	60 (414)
Elongation in 2 in. or 50 mm (or 4D), min. %		
Basic minimum elongation for walls 5/16 in (7.9 mm) and over in thickness, longitudinal strip tests, and for all small sizes tested in full section	30	20
When standard round 2-in. or 50-mm gage or smaller proportionally sized specimen with the gage length equal to 4D (4 times the diameter) is used.	22	20
For longitudinal strip tests a deduction shall be made for each 1/32 in. (0.79 mm) decrease in wall thickness below 5/16in. (7.9 mm) from the basic minimum elongation of the following percentage points	1.50 <sup>A</sup>	1.00

## Minimum Elongation Values

Wall Thickness in.	Elongation in 2 in. or 50 mm. min. %		
	mm	All grades except T91	Grade T91
5/16 (0.312)	7.94	30	20
3/32 (0.281)	7.14	28	19
1/4 (0.250)	6.35	27	18
7/32 (0.219)	5.56	26	17
3/16 (0.188)	4.76	24	16
5/32 (0.156)	3.97	22	15
1/8 (0.125)	3.18	21	14
3/32 (0.094)	2.38	20	13
1/18 (0.062)	1.59	18	12



## Comparison of tolerances

Comparison of tolerances

### Cold Finished Pipes and Tubes

Specification		Outside Diameter				Wallthickness	
<b>ASTM</b>							
A 450		< 25,4mm	< 38,1mm	< 50,8mm	> 50,8 mm		
		+/- 0,10mm	+/- 0,15mm	+/- 0,20mm	+/-0,25mm	-0/+20% (min. wall)	
						(average wall +/-10% not included)	
A 530		< 48,3mm > 48,3mm					
		+0,4/-0,8mm +/-0,8mm				+/-12,5%	
A 269		< 38,1mm		< 63,5mm			
		+/- 0,13mm		+/-0,25mm		+/-10%	
<b>EN-ISO 1127 (previously: DIN 2462)</b>							
Tol.class	TC D2	+/-1,00% min. +/-0,5mm				T 2 +/-12,5% min. +/-0,40 mm	
	TC D3	+/-0,75% min. +/-0,3mm				T 3 +/-10% min. +/-0,20 mm	
	TC D4	+/-0,50% min. +/-0,1mm				T 4 +/-7,5% min. +/-0,15 mm	
<b>DIN 28180 (valid only for heatexchanger dimensions)</b>							
Tol.class		16-20mm	25mm	30mm	38mm	< 2 mm	> 2 mm
	TC 1	+/-0,10mm	0,12mm	0,15mm	0,20mm	+/-0,2mm	+/-10%
	TC 2	0,30mm	0,30mm	0,30mm	0,40mm	+/-0,2mm	+/-10%
	TC 3	-	-	-	-	+/-0,2mm	+15/-10%
<b>NFA Quality F (cold finished)</b>							
49117	Quality F (cold finished)	+/-0,75% with a minimum tolerances of +/-0,30mm				+/-10% with a minimum of +/-0,20 mm	
49217		< 25,4mm	< 38,1mm	< 50,8mm	>50,8mm		
	Ferritic	+/-0,10mm	+/-0,15mm	+/-0,20mm	+/-0,50%	normally +/-10%	
	Austenitic+Austenitic-Ferritic	+/-0,25mm	+/-0,25mm	+/-0,25mm	+/-0,50%	(on request:-0+20% min. wall)	
<b>BS CFS</b>							
3059	Part 2 Austenitic	+/-0,50% with a minimum tolerances of +/-0,15mm				+/-10%(<3,25 mm) +/-7,5%(>3,25 mm)	
3605	Part 1 Austenitic	+/-0,75% with a minimum tolerances of +/-0,20mm				+/- 10% min. +/- 0,15 mm	
3606		< 25mm	< 38mm	< 50mm			
	Ferritic	+/-0,10mm	+/-0,15mm	+/-0,20mm		+/-10%	
	Austenitic	+/-0,15mm	+/-0,15mm	+/-0,20mm		(on request:-0/+20% or -0/+22%)	

B.W.G.-Birmingham Wire Gauge or Stubs Iron Wire Gauge

BWG 7	4.572mm
BWG 8	4.191mm
BWG 10	3.404mm
BWG 11	3.048mm
BWG 12	2.769mm
BWG 13	2.413mm
BWG 14	2.108mm
BWG 16	1.651mm
BWG 18	1.245mm
BWG 20	0.889mm
BWG 22	0.771mm

## Low Carbon Steel Tubes for Heat exchanger and Boilers

### Chemical composition and mechanical properties

STANDARD	ASTM-A	179	214	192	226
Manufacturing Process		Seamless	ERW	Seamless	ERW
Chemical Analysis					
C	%	0.06-0.18	0.18 max	0.06-0.18	0.06-0.18
Mn	%	0.27-0.63	0.27-0.63	0.27-0.63	0.27-0.63
P max	%	0.035	0.035	0.035	0.035
S max	%	0.035	0.035	0.035	0.035
Si max	%			0.25	0.25

### Mechanical Properties

Tensile Strength	min KSI [MPA]	47 [325]	47 [325]	47 [325]	47 [325]
Yield Strength	min KSI [MPA]	26 [180]	26 [180]	26 [180]	26 [180]
Elongation in 2 in.	min %	35	35	35	35

### Comparison of International Specifications & Grades

ASTM	DIN	BS	NFA	JIS
A 179	17175	3602 Pt1	A 49215	G 3461
	ST 35.8/1	3059 Pt2 St 360	TU 37C	STB 340
A 192	17175 ST 35.8/1	CAT2	A 49215 TU 37C	JIS
		3602 Pt1		G3461
		3059 Pt2		STB 340
A 214	17177 ST 37.8/1	BS 3059 Pt2	A 49242	G 3461
		3602 Pt1	A 49245	STB 340
		ERW 360 CAT2	TS 37C	
A 226	17177 ST 37.8/1	BS 3059 Pt2	A 49242	G 3461
		BS 3602 Pt1	A 49245	STB 340
		ERW 360 CAT2	TS 37C	

## Medium Carbon Steel Teel Tubes for Heat-exchanger and Boiler

### Chemical composition and mechanical properties

Material Standard		ASTM-A 210						
Manufacturing Process		Seamless						
Grade	C max	Mn	P max	S max	Si min	min YS KSI [MPa]	min TS KSI [MPa]	EI (%)
A1	0.27	0.93 max	0.035	0.035	0.1	37 [255]	60 [415]	30
C	0.35	0.29-1.06	0.035	0.035	0.1	40 [275]	70 [485]	30

Material Standard		ASTM-A 556						
Manufacturing Process		Seamless						
Grade	C max	Mn	P max	S max	Si min	min YS KSI [MPa]	min TS KSI [MPa]	EI (%)
A2	0.18	0.27-0.63	0.035	0.035	...	26[180]	47[320]	35
B2	0.27	0.29-0.93	0.035	0.035	0.10	37[260]	60[410]	30
C2	0.30	0.29-1.06	0.035	0.035	0.10	40[280]	70[480]	30

Comparison of International Specifications & Standards				
ASTM-A	BS	DIN	NFA	JIS
210 A1	3602 Pt1	17175	A 49215/9	G 3461
A556 B2	ST 430 Cat2	St 45.8/1	T 442 b/F	ST B 410
210 Gr. C	3606	DIN 17175	...	...
A 556 Gr. C2	St 440 Cat.2	17 Mn 4	...	...

## Alloy Steel Tubes for Heatexchanger and Boilers

### Chemical composition and mechanical properties

Material Standard		ASTM-A 209				
Manufacturing Process		Seamless				
Chemical Requirements						
Grade	Element					
	C	Mn	P	S	Si	Mo
T1	0.10-0.20	0.30-0.80	0.025	0.025	0.10-0.50	0.44-0.65
T1a	0.15-0.25	0.30-0.80	0.025	0.025	0.10-0.50	0.44-0.65
T1b	0.14 max	0.30-0.80	0.025	0.025	0.10-0.50	0.44-0.65

Tensile Requirements			
Grade	Tensile Strength, min	Yield Strength, min	Elongation
	KSI (MPa)	(0.2% offset), min, KSI (MPa)	in 2 in. or 50 mm, (or 4D), min, %
T1	55 [380]	30 [205]	30
T1a	60 [415]	32 [220]	30
T1b	53 [365]	28 [195]	30

## Alloy Steel Tubes for Heat exchanger and Boiler

### Chemical composition and mechanical properties

Material Standard		ASTM-A 199 (94)						
Manufacturing Process		Seamless						
Chemical Requirements								
Element	C	Mn	P	S	Si	Cr	Mo	Others
<b>Grade</b>								
T4	0.05 - 0.15	0.30-0.60	0.025	0.025	0.50-1.00	2.15-2.85	0.44-0.65	...
T5	0.15 max	0.30-0.60	0.025	0.025	0.50 max	4.00-6.00	0.45-0.65	...
T9	0.15 max	0.30-0.60	0.025	0.025	0.25-1.00	8.00-10.00	0.90-1.10	...
T11	0.05 - 0.15	0.30-0.60	0.025	0.025	0.50-1.00	1.00-1.50	0.44-0.65	...
T21	0.05 - 0.15	0.30-0.60	0.025	0.025	0.50 max	2.65-3.35	0.80-1.06	...
T22	0.05 - 0.15	0.30-0.60	0.025	0.025	0.50 max	1.90-2.60	0.87-1.13	...
T91	0.08 - 0.12	0.30-0.60	0.020	0.010	0.20-0.50	8.00-9.50	0.85-1.05	*

\* Ni 0.40 max; V 0.18-0.25; Cb 0.06-0.10; N 0.03-0.07; Al 0.04 max

Tensile Requirements			
Grade	Tensile Strength, min	Yield Strength, min (0.2% offset), min,	Elongation in 2 in. or 50 mm, (or 4D), min, %
	KSI (MPa)	KSI (MPa)	
All Grades			
Except T91	60 [415]	25 [170]	30
Grade T91	85 [585]	60 [415]	20

Material Standard:		ASTM A 213									
Manufacturing Process		Seamless									
Grade	C	Si	Mn	P	S	Cr	Mo	V	YS min KSI [MPa]	TS min KSI [MPa]	El (%)
T2	0.10-0.20	0.10-0.30	0.30-0.61	0.025	0.025	0.50-0.81	0.44-0.65	...	30[205]	60[415]	30
T5	0.15 max	0.50 max	0.30-0.60	0.025	0.025	4.00-6.00	0.45-0.65	...	30[205]	60[415]	30
T5b	0.15 max	1.00-2.00	0.30-0.60	0.025	0.025	4.00-6.00	0.45-0.65	...	30[205]	60[415]	30
T5c <sup>1</sup>	0.12 max	0.50 max	0.30-0.60	0.025	0.025	4.00-6.00	0.45-0.65	...	30[205]	60[415]	30
T9	0.15 max	0.25-1.00	0.30-0.60	0.025	0.025	8.00-10.00	0.90-1.10	...	30[205]	60[415]	30
T11	0.05-0.15	0.50-1.00	0.30-0.60	0.025	0.025	1.00-1.50	0.44-0.65	...	30[205]	60[415]	30
T12	0.05-0.15	0.50 max	0.30-0.61	0.025	0.025	0.80-1.25	0.44-0.65	...	32[220]	60[415]	30
T17	0.15-0.25	0.15-0.35	0.30-0.61	0.025	0.025	0.80-1.25	...	0.15	30[205]	60[415]	30
T21	0.05-0.15	0.50 max	0.30-0.60	0.025	0.025	2.65-3.35	0.80-1.06	...	30[205]	60[415]	30
T22	0.05-0.15	0.50 max	0.30-0.60	0.025	0.025	1.90-2.60	0.87-1.13	...	30[205]	60[415]	30
T91 <sup>2</sup>	0.08-0.12	0.20-0.50	0.30-0.60	0.020	0.010	8.00-9.50	0.85-1.05	0.18-0.25	60[415]	85[585]	20
T92 <sup>3</sup>	0.07-0.13	0.50 max	0.30-0.60	0.020	0.010	8.50-9.50	0.30-0.60	0.15-0.25	64[440]	90[620]	20
18Cr-2Mo <sup>4</sup>	0.025 max	1.00 max	0.30-0.60	0.040	0.030	17.5-19.5	1.75-2.50	...	40[275]	60[415]	20

<sup>1</sup> Grade T5c shall have a titanium content of not less than 4 times the carbon content and not more than 0.70%.

<sup>2</sup> Grade T91 - other elements: Cb 0.06 - 0.10 · N 0.030 - 0.070 · Ni 0.40 max · Al 0.04 max.

<sup>3</sup> Grade T92 - other elements: W 1.50 - 2.00 · Cb 0.04 - 0.09 · B 0.001 - 0.006 · N 0.03 - 0.07 · Ni 0.40 max · Al 0.04 max.

<sup>4</sup> Grade 18Cr-2Mo shall have Ti + Cb = 0.20 + 4(C + N) min, 0.80 max, other elements N max 0.035 · (Ni + Cu) max 1.00.

## Chemical composition and mechanical properties

Material Standard		ASTM-A 334							
Manufacturing Process:		Seamless or Welded							
Chemical Analysis									
Grade	C max	Mn	P max	S max	Si	Ni	min YS KSI [MPA]	min TS KSI [MPA]	El (%)
1	0.30	0.40-1.06	0.025	0.025			30 [205]	55 [380]	35
3	0.19	0.31-0.64	0.025	0.025	0.18-0.37	3.18-3.82	35 [240]	65 [450]	30
6	0.30	0.29-1.06	0.025	0.025	0.10 min		35 [240]	60 [415]	30
7	0.19	0.90 max	0.025	0.025	0.13-0.32	2.03-2.57	35 [240]	65 [450]	30
8	0.13	0.90 max	0.025	0.025	0.13-0.32	8.40-9.60	75 [520]	100 [690]	22
91	0.20	0.40-1.06	0.025	0.025		1.60-2.24	46 [315]	63 [435]	28
112	0.10	0.60 max	0.025	0.025	0.35 max	35.0-37.0	35 [240]	65 [450]	18

1 Cu 0.75-1.25  
2 Cr 0.50 max · Co 0.50 max · Mo 0.50 max

## Comparison of International Specifications & Grades

ASTM	DIN	BS	NFA	JIS
A209 T1/a/b	VD-TÜV	3606	...	G 3462
A161 T1/A335 P1	16Mo5	St 245	...	ST BA 12
A213 T2	...	...	A 49-213 15 CD 2-05	...
A 199 T4	...	...	...	...
A 199/213 T5/P5	17176	3604/6	A 49 213	G3462
A 200/A 335	12 Cr Mo 195	ST 625	TU Z 10CD505	ST BA 25
A 199/213 T9/P9	17176	3604	A 49213	...
A 200/A 335	X 12CrMo9.1	ST 629	Z 10CD9	...
A 199 T11/	17176	3059	A49213/5/9	G 3462
A 213 T11/12/P11/12	13CrMo44	3604/6	TU 13 CD 4.04	STBA 22,33
A 200/A335		ST 620-460	TU 10 CD 505	...
A 213 T17	...	...	...	...
A 199/A213/A200/T21	...	...	...	...
A 199/A213 T22/P212	DIN 17176	3059	A 49213/5/9	G 3462
A 200/A335	10 Cr Mo 910	3604/6 ST 620-490	TU 10CD 910	STBK 24
A 199/A213 T91/P91	17175	...	A 49213	...
A 200/A 335	X10CrMoYNb 9.1	....	Z 10 CD Nb Y09-01	...
A 213 T92	...	...	...	...
A213 18Cr2Mo	...	...	...	...
A 334	DIN	BS	NFA	JIS
Gr.1	17173 TTSt 35 N	3603	...	G 3464 STBL 39
Gr.3	10 Ni 14	503LT	49215/30/330 TU 10 N 14	STBL 46
Gr.6	DIN 17179 TST E285	430 LT	TU 42 BT	...

## Copper. Copper Alloys

Copper tubes material: C12200, C11000, C44300 HSn70-1, C68700 HAI77-2, C70600 BF210-1-1, C71500 BFe30-1-1,  
Copper tubes standards: ASTM B68, ASTM B88, ASTM B111-99, EN 1057  
ASTM B75, GB/T8890-1998

Inner grooved copper tube Specification: 4.00~15.88mm  
The High Precise Plain Copper Tube Specification: 3.80~28.57mm  
Pancake coil copper tube Specification: 4.00~22.22mm  
Copper Alloy: copper tubes Specification: 6~108mm  
Copper capillary tube: Specification: 1.0~4.0mm  
copper fin tubes, fin copper tubes

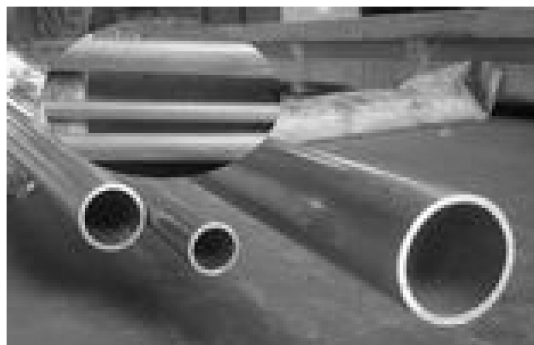

Standard	Copper alloy No.	Chemical Composition		Mechanical Properties			
		CU%	P%	Temperature	Tensile strength (Mpa)	Elongation (%)	Average Grain Size (mm)
ASTM B68	C12200	≥99.9	0.015 to 0.040	O60	≥205	≥40	>0.040
				O50	≥245	-	0.015 ~ 0.040

Standard	Copper Alloy No.	Chemical Composition		Mechanical Properties			
		CU%	p%	Temper	Tensile strength(Mpa)	Elongation(%)	Grain Size (mm)
ASTM B88	C11000	99.90	-	O60	≥200	-	≥0.040
				O50	≥200	-	≥0.025
	C12200	99.90	0.015~0.040	H58	≥250	-	-
JIS H3300	C1100	99.90	0.015~0.040	O	≥205	≥40	-
				OL	245~ 325	-	-
				H	≥265	-	-
	C1220	99.90	0.015~0.040	O	≥205	≥40	0.025~ 0.060
				OL	≥205	≥40	≤0.040
				1/2H	245~ 325	-	-
H	≥255	-	-				
ASTM B75	C11000	99.90	-	O60	≥205	-	≥0.040
				O50	≥205	-	≤0.040
	C12200	99.90	0.015~0.040	H58	≥250	-	-
				H80	≥310	-	-
EN 1057	-	99.90	0.015~0.040	R220	≥220	≥40	-
				R250	≥250	≥30 or 20	-
				R290	≥290	≥3	-

Copper Alloy No.	Temper	O.D.(inch)	Thickness(inch)	Standard
ASTM B111 C44300 HSn70-1	O61	1/2 "~1-1/5"	0.035"~0.1"	ASTM B111-99
ASTM B111 C68700 HAI77-2				GB/T8890-1998
ASTM B111 C70600 BF210-1-1	O61 H55			JIS H3300:1997
ASTM B111 C71500 BFe30-1-1	O61 HR55			

# U-Tubes for Heat Exchangers

## Definition

U-Tubes as per this technical delivery standard are bend hairpin tubes which are usually used in heat exchangers.

## Scope

This technical delivery standard refers to U-bend tubes with radii from 1,5 D. Tolerances for smaller radii have to be agreed with the customer.

Hairpin U-bend tube with one 180 deg. bend

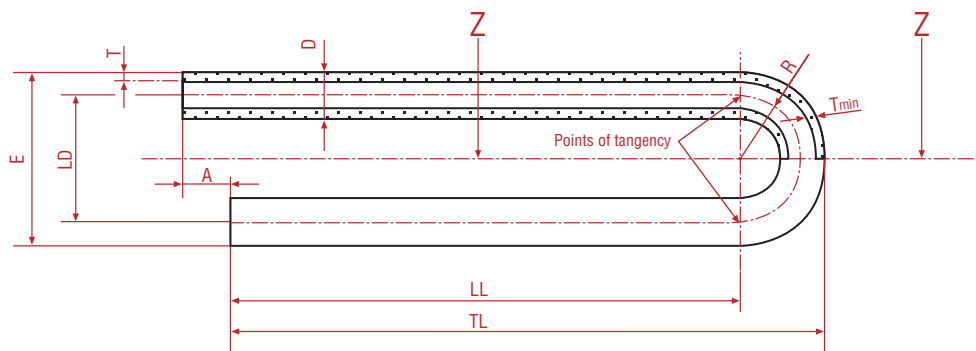

Square U-bend tube with two 90 deg. bends

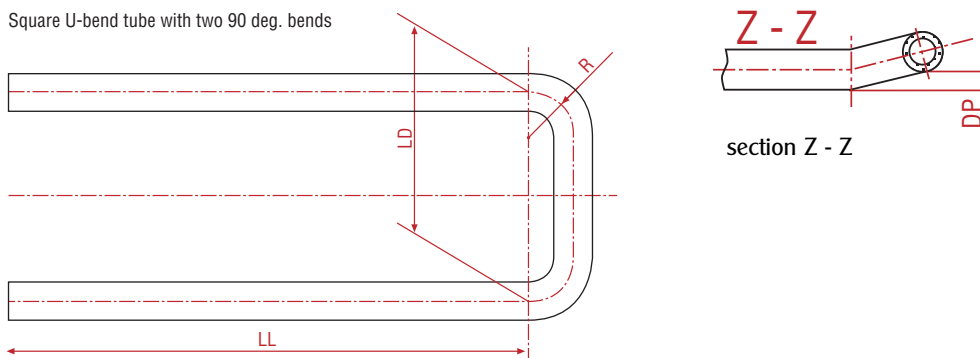

## The meaning of measurements and symbols:

<b>A</b>	LEG LENGTH DIFFERENCE	<b>R</b>	CENTERLINE BEND RADIUS
<b>E</b>	(2R + D) 2X RADIUS PLUS OUTSIDE DIAMETER	<b>Rmin.</b>	MIN. RADIUS
<b>D</b>	NOMINAL OUTSIDE DIAMETER	<b>T</b>	WALL THICKNESS
<b>Dmax.</b>	MAX. OUTSIDE DIAMETER	<b>Tmin.</b>	MIN. WALL THICKNESS IN OUTSIDE BENDING AREA
<b>Dmin.</b>	MIN. OUTSIDE DIAMETER	<b>SW</b>	SMALLEST WALL THICKNESS OF STRAIGHT TUBE
<b>LD</b>	LEG LENGTH DISTANCE MEASURED FROM POINTS OF TANGENCY	<b>O</b>	OVALITY
<b>LL</b>	LEG LENGTH	<b>DP</b>	DEVIATION FROM PLANE OF BEND
<b>TL</b>	TOTAL LENGTH	<b>Z</b>	Section